

POLYBOX™

Operation Manual

Thank you for purchasing the PolyBox™ from Polymaker! With PolyBox™ you'll experience no more 3D printing problems caused by filaments absorbing moisture such as extreme oozing, rough surface quality, weaker 3D prints, 3D printer damages and so on!

PACKAGE CONTENTS

Your PolyBox™ package should contain the following:

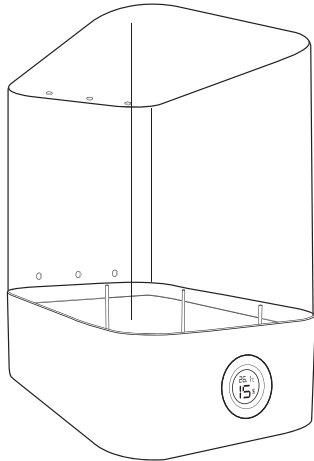

PolyBox™
(cover + base)

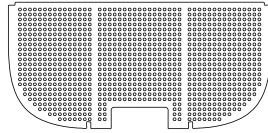

Front Grid
x 1

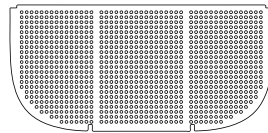

Back Grid
x 1



Rods
x 4

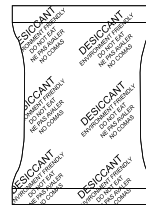

100g Silica
Gel Sachets x 4



Rubber Plug
x 6



Thermo-Hygrometer
x 1



Battery LR44
x 1

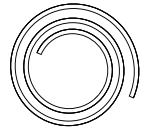

Filament Guide
150cm

ESSENTIAL PARTS OF THE POLYBOX™

- 1 Base
- 2 Cover
- 3 Rubber Plugs
- 4 Desiccant Compartments
- 5 Thermo-Hygrometer

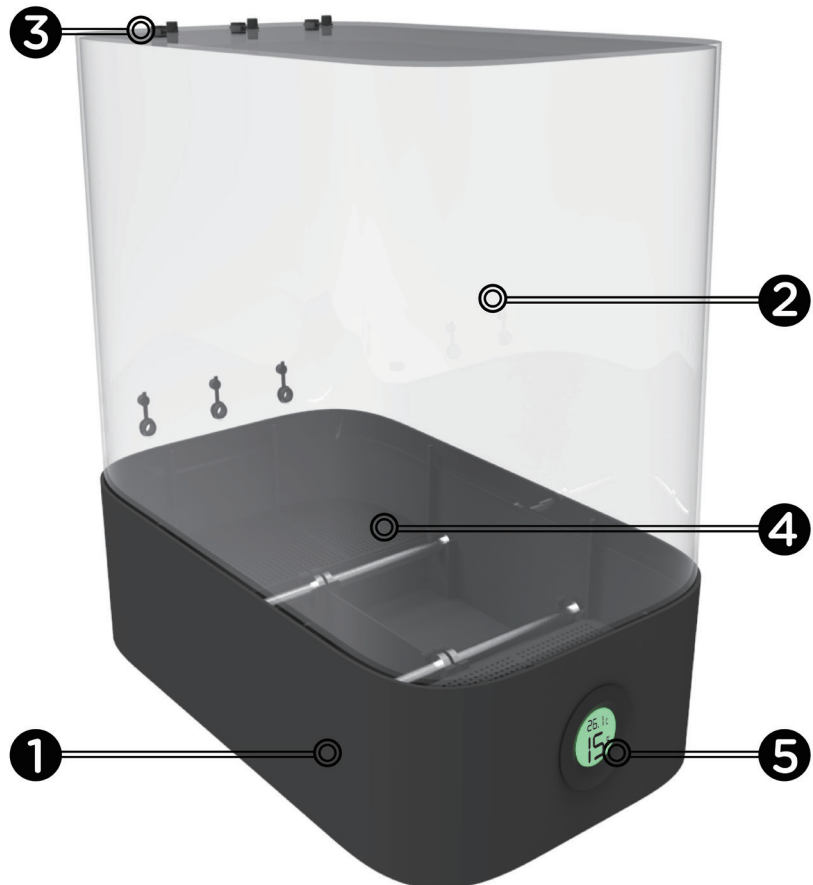

SETTING UP YOUR POLYBOX™

- 1 To install the hygrometer battery**
Slide down the hygrometer battery cover.
Remove the battery from the package, insert it in the designed compartment and put back the cover. Check if the front display switches on. When you notice that the hygrometer display is fading, replace the button battery 1.5V LR44.

Note: The provided battery will last approximately 3 months.



- 2 To install the rods**
Slide two bearings onto both ends of the steel rod, then snap the rod and bearings into the PolyBox™



- 3 To install the desiccant sachets**
Remove one set of desiccants from the package and check if the sealed bag is intact. If there are any leaks, please dry the sachets before using it. The provided desiccant can be dried at 80-90°C for 8 hours to restore the drying capacity and be reused.

Note: other types of desiccant may not have the ability to recover and be reused.

Do not expose the desiccant sachets to the air for too long. We highly recommend silica gel for the type of desiccant.

Put the two desiccant bags into the PolyBox™, one in each compartment as shown below.
Close the two compartments with the two grids.

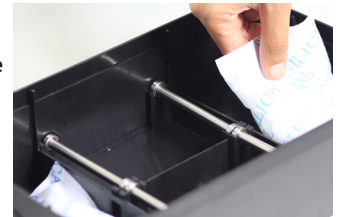

- 4 To install the filament guide**
Cut the filament guide according to your need (Distance from the PolyBox™ to the 3D printer) and insert it in the rubber holes on the back or on the top.



- 5 To place the spool**
Place the spool on the rods as shown below and make sure it rolls freely.

Note: Make sure the material is fully dried before putting it in the PolyBox™.

Insert the filament in the hole from the inside and push it until it exits from the other side of the filament guide as shown below.

With your hands carefully slide the cover in the base as shown below. You should feel a small friction which ensures the fit. Make sure the cover fits correctly in the base to ensure an airtight environment for the spools.
Do not open the PolyBox™ too frequently and close all the unused rubber plugs to preserve the desiccant.

Gently pull the filament out to check if the spool rolls smoothly.

After 10-30min you should already see the inside humidity dropping below 15%. The time will depend on the room humidity. The hygrometer should always display a humidity level below 15%.

Note : The minimum humidity level that can be displayed is 10%

If the hygrometer displays a humidity level above 20%, replace the desiccant.

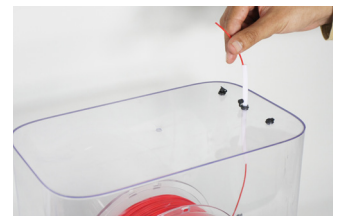
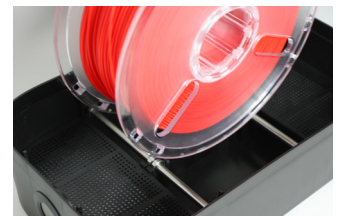

Caution:

Be careful, at the end of the spool, the filament might get stuck in the PolyBox™ and the 3d printer can drag the PolyBox™.

