

CUT 60mm BOLT TO 50mm AND CHASE THREADS

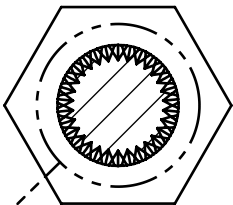

SECTION A-A

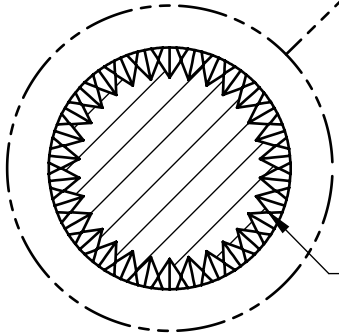

MAKE TEETH WITH M6 x 1.0 TAP. TEETH MUST BE SHARP ALL THE WAY AROUND.

DETAIL B
SCALE 4 : 1

NOTES:

1. MAKE PART FROM MCMMASTER PART # 91287A160 OR EQUIVALENT.

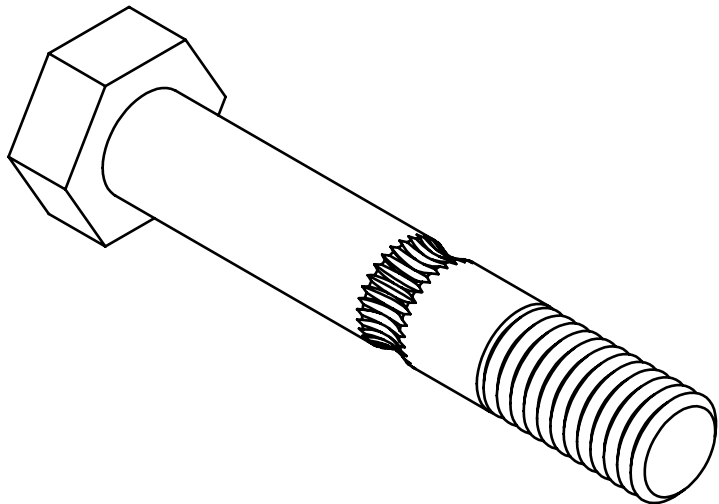

DRAWN BY SINNEMA		2/2/2014	
MATERIAL			
UNLESS OTHERWISE SPECIFIED DIMENSIONS ARE IN MILLIMETERS. TOLERANCES ARE:			
DECIMALS	ANGLES		
.X ± .75	X° ± 1°		
.XX ± .25	63		
.XXX ± .125			
.XXXX ± .050			
BREAK EDGES .005/.020			
FILLET RADIUS .005/.020			



Sinnema Design Services

seth.sinnema@gmail.com
Phone: (303) 250-8218
Fax: 1-267-393-7872

TITLE Hobbed Bolt 26			
SIZE A	DWG NO.		REV. IR
SCALE 2:1	DO NOT SCALE DRAWING	SHEET 1 OF 1	