

Version	Date	Description
IR	6.4.17	New part number for silkscreen version
A	5/15/19	Add masking for usb cut out

**NOTES(UNLESS OTHERWISE SPECIFIED):**

1. ALL COMPONENTS RoHS COMPLIANT
2. 3D MODEL GOVERNS DIMENSIONS NOT SHOWN ON PRINT  $\triangle 1\text{mm}$
3. MATERIAL: 5052 H32 AL, 2.03 MM THICK
4. BREAK ALL CORNERS PRIOR TO POWDER COATING
5. MASK ALL THREADS PRIOR TO POWDER COATING AND SEE PAGE 6 FOR FURTHER MASKING DETAILS AND WHERE OVERSPRAY IS ALLOWED
6. POWDER COAT WITH CARDINAL COLOR C241-BK109. COATING THICKNESS: 0.05mm TO 0.12mm

DRAWN BY: <b>West</b>	DATE: <b>3/27/19</b>		626 West 66th Street Loveland, Colorado 80538, USA Phone +1-970-377-1111 www.alephobjects.com	
MATERIAL: <b>See notes</b>			TITLE <b>electronics chassis</b>	
UNLESS OTHERWISE SPECIFIED DIMENSIONS ARE IN MILLIMETERS. TOLERANCES ARE: DECIMALS      ANGLES .X $\pm$ .75      X $^{\circ}$ $\pm$ 1 $^{\circ}$ .XX $\pm$ .25 .XXX $\pm$ .125 .XXXX $\pm$ .050		SIZE      DWG NO. <b>A</b> <b>PP-FP0172</b>		REV. <b>A</b>
BREAK EDGES 0.1/0.5 FILLET RADIUS 0.1/0.5		SCALE      NA	DO NOT SCALE DRAWING	SHEET      1 of 8

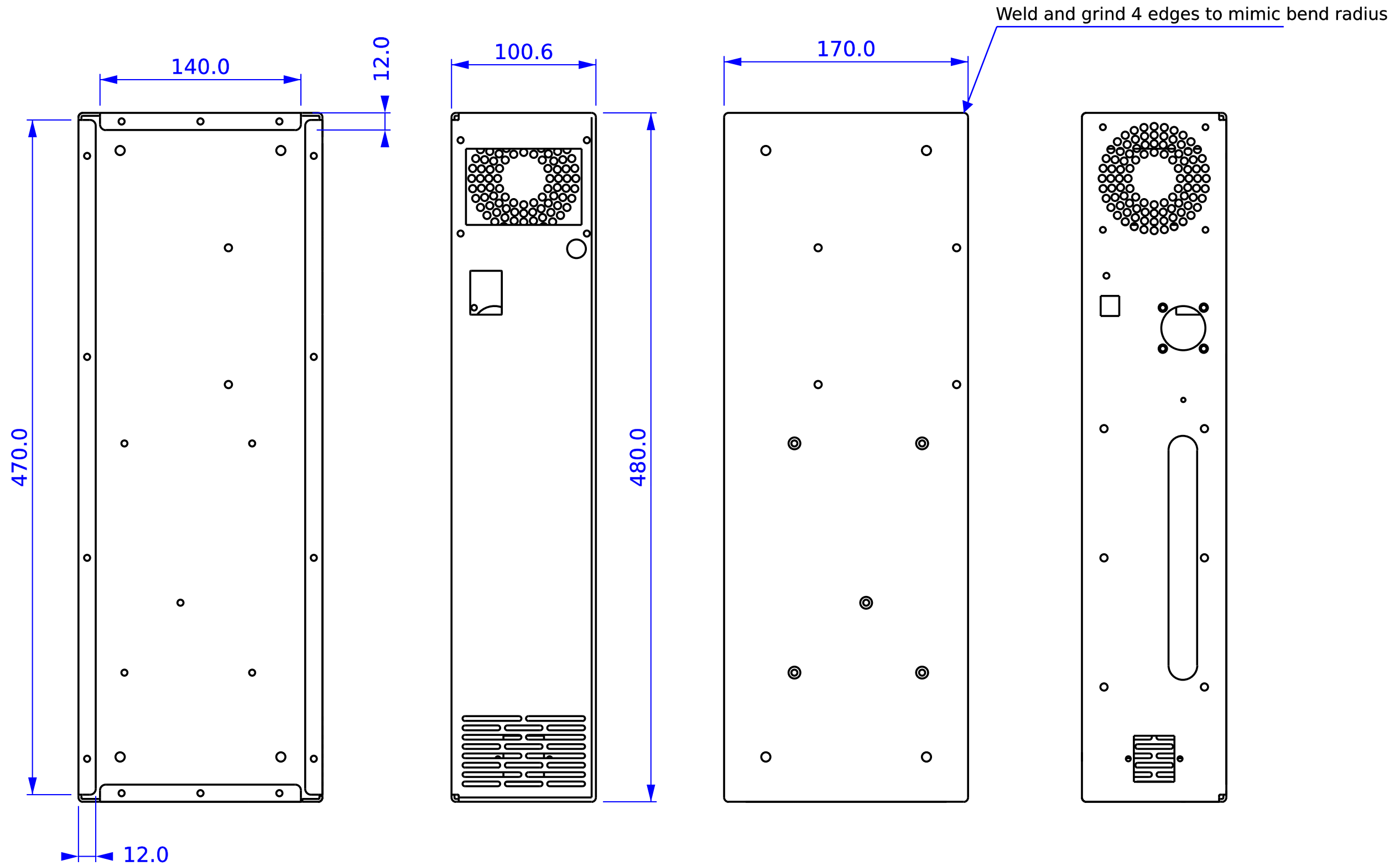

TITLE			
electronics chassis			
SIZE	DWG NO.	REV.	
A	PP-FP0172	A	
SCALE	NA	DO NOT SCALE DRAWING	SHEET 2 of 8

4 X TSO-M25-1400Z1 BLIND INSERTS  
INSTALL STANDOFF TOWARD INSIDE

SHARP CORNERS ACCEPTABLE

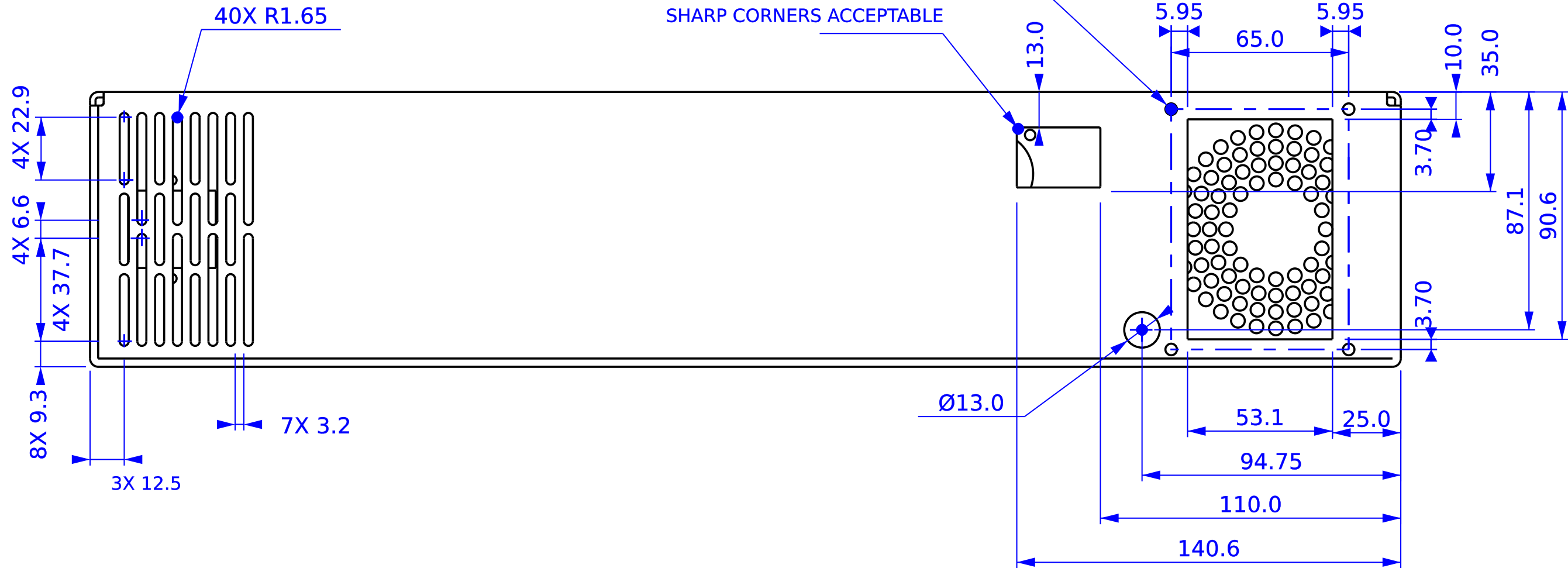

TITLE			
electronics chassis			
SIZE	DWG NO.	REV.	
A	PP-FP0172	A	
SCALE	NA	DO NOT SCALE DRAWING	SHEET 3 of 8

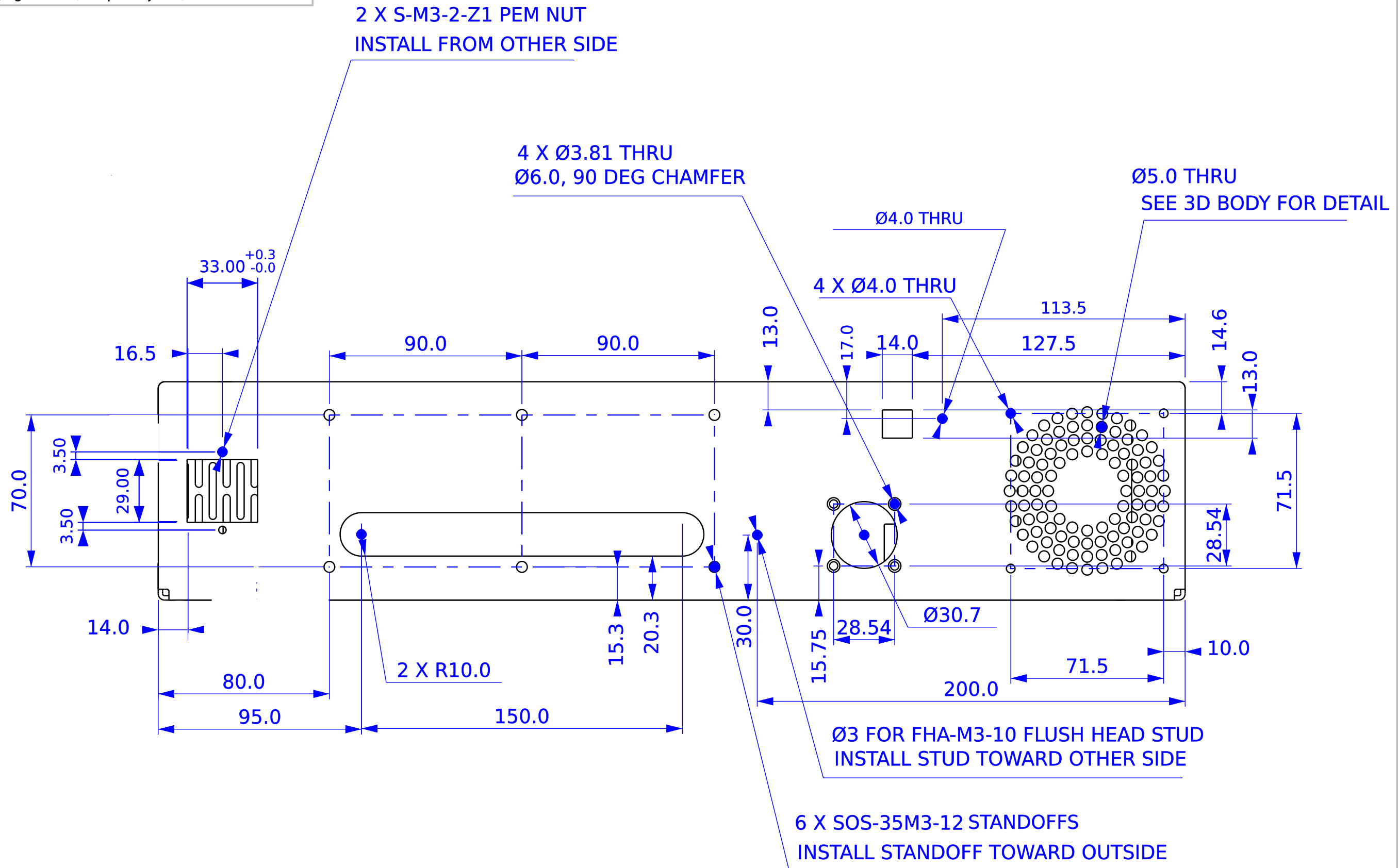

TITLE			
electronics chassis			
SIZE	DWG NO.	REV.	
A	PP-FP0172	A	
SCALE	NA	DO NOT SCALE DRAWING	SHEET 4 of 8

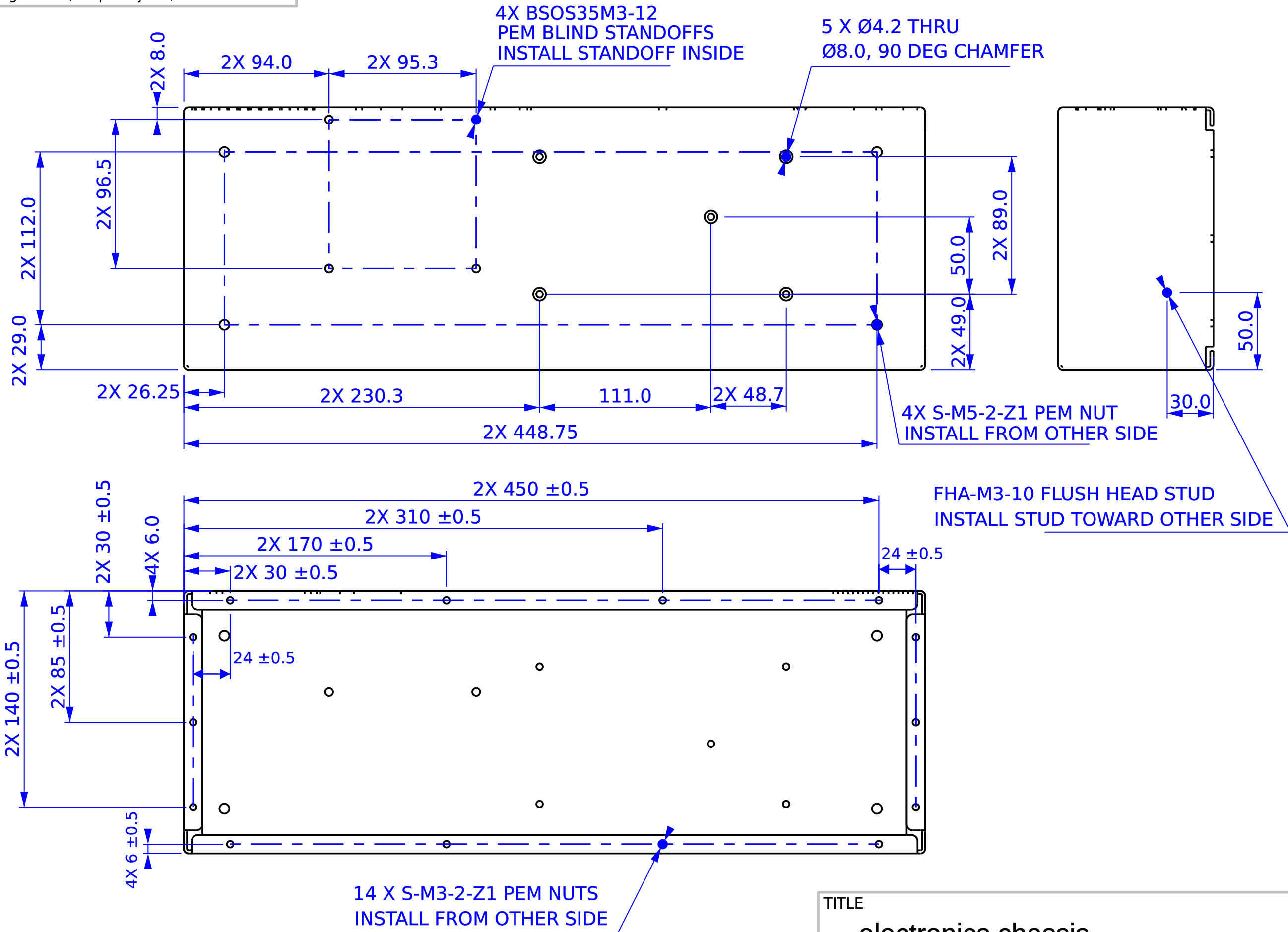

TITLE			
electronics chassis			
SIZE	DWG NO.	REV.	
A	PP-FP0172	A	
SCALE	NA	DO NOT SCALE DRAWING	SHEET 5 of 8

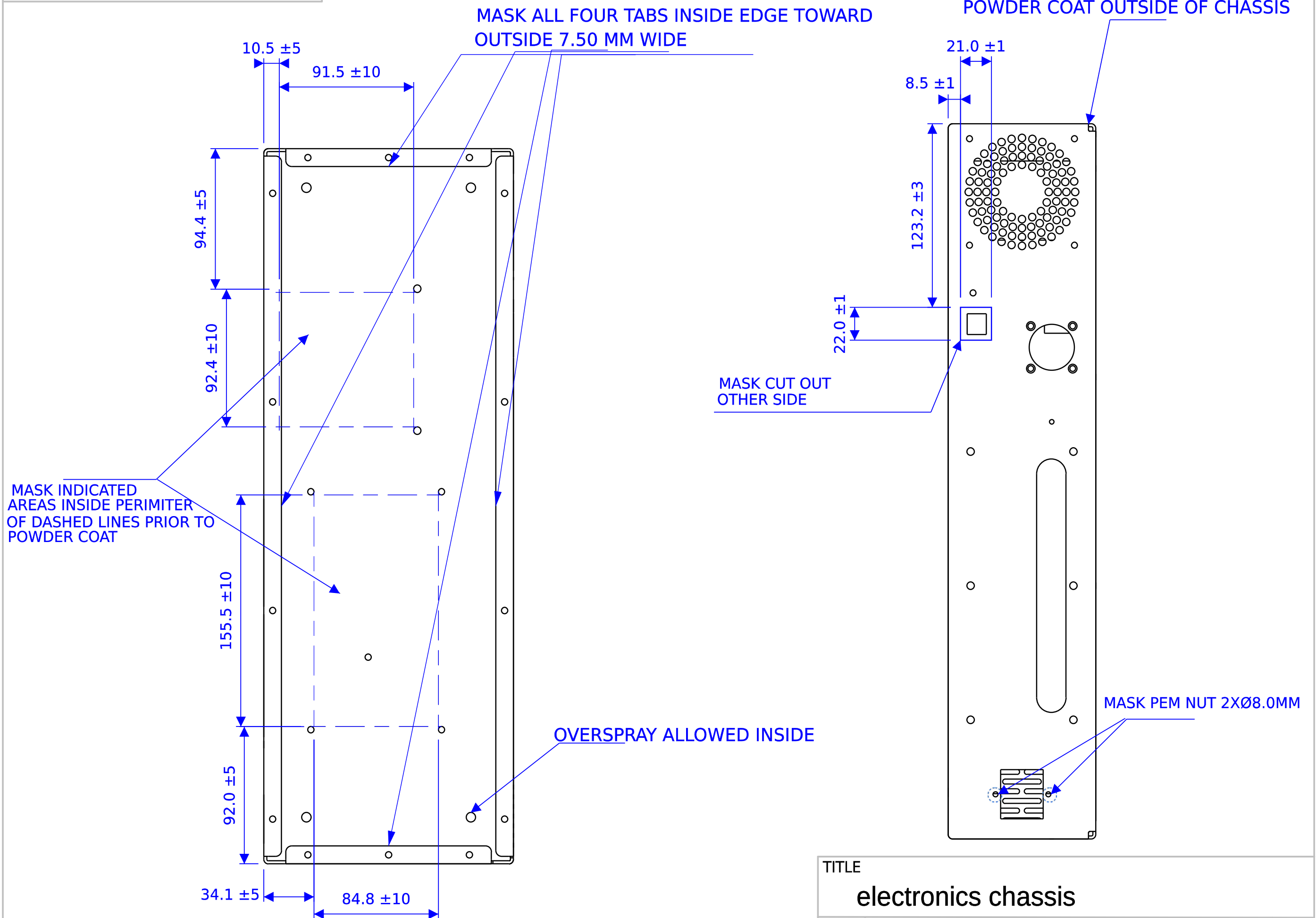

TITLE			
electronics chassis			
SIZE	DWG NO.	REV.	
A	PP-FP0172	A	
SCALE	DO NOT SCALE DRAWING	SHEET	6 of 8
NA			

GRAPHICS NOT TO SCALE. FOR REFERENCE ONLY

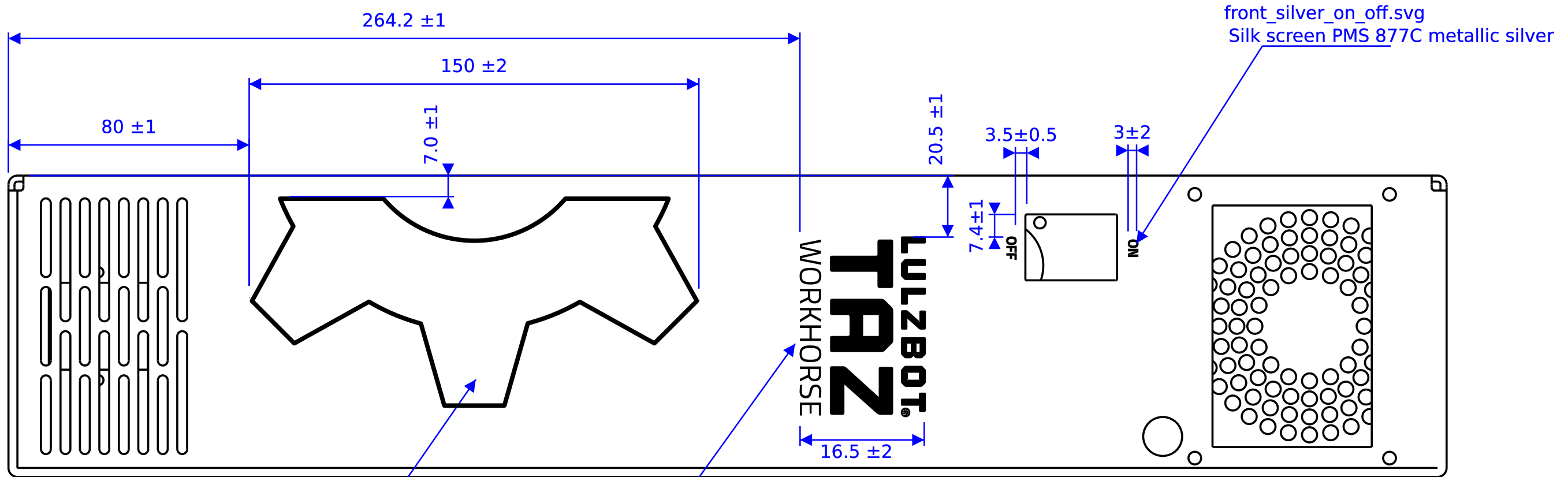

TITLE			
electronics chassis			
SIZE	DWG NO.	REV.	
A	PP-FP0172	A	
SCALE	NA	DO NOT SCALE DRAWING	SHEET 7 of 8

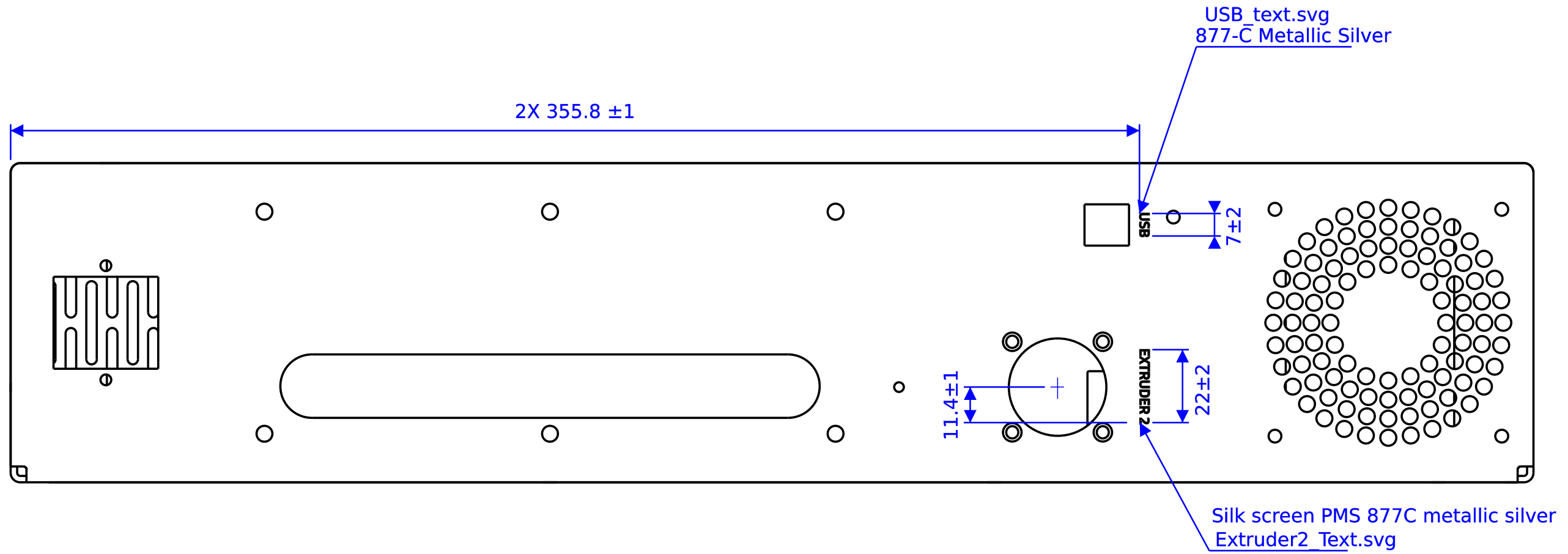

GRAPHICS NOT TO SCALE. FOR REFERENCE ONLY

TITLE			
electronics chassis			
SIZE	DWG NO.	REV.	
A	PP-FP0172	A	
SCALE	NA	DO NOT SCALE DRAWING	SHEET 8 of 8