

Notes:

1. Material: RoHS compliant 12AWG (.08") Aluminum
2. Break all sharp edges prior to powder coat. Mask all threads prior to powder coat.
3. Part is to be powder coated with Cardinal color C241-BK109. Thickness of coating must not exceed 0.08mm.

4. Ink mark in area indicated with first initial of your company name

DRAWN BY
SINNEMA 7/18/14

MATERIAL
See Notes

UNLESS OTHERWISE SPECIFIED
DIMENSIONS ARE IN MILLIMETERS.
TOLERANCES ARE:

DECIMALS	ANGLES
.X ± .75	X° ± 1°
.XX ± .25	
.XXX ± .125	
.XXXX ± .050	63

BREAK EDGES .005/.020
FILLET RADIUS .005/.020



Sinnema Design Services

seth.sinnema@gmail.com
Phone: (303) 250-8218
Fax: 1-267-393-7872

TITLE

Left Plate, Mini

SIZE A DWG NO.

PP-FP0055

REV. D

SCALE

1:3

DO NOT SCALE DRAWING

SHEET

1 OF 3

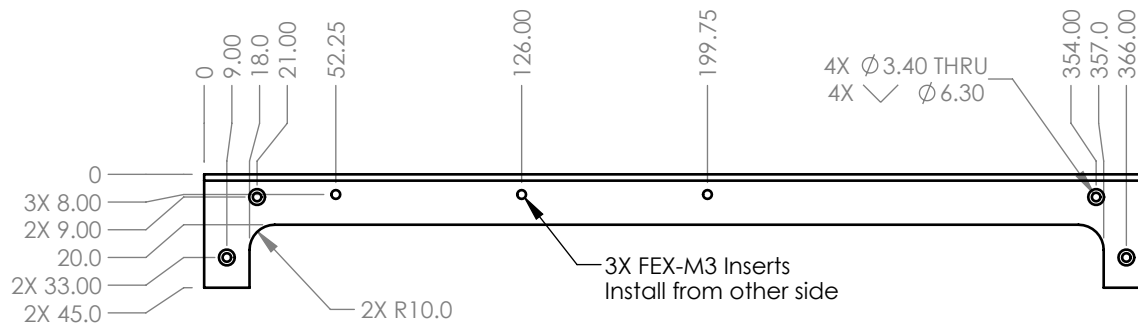
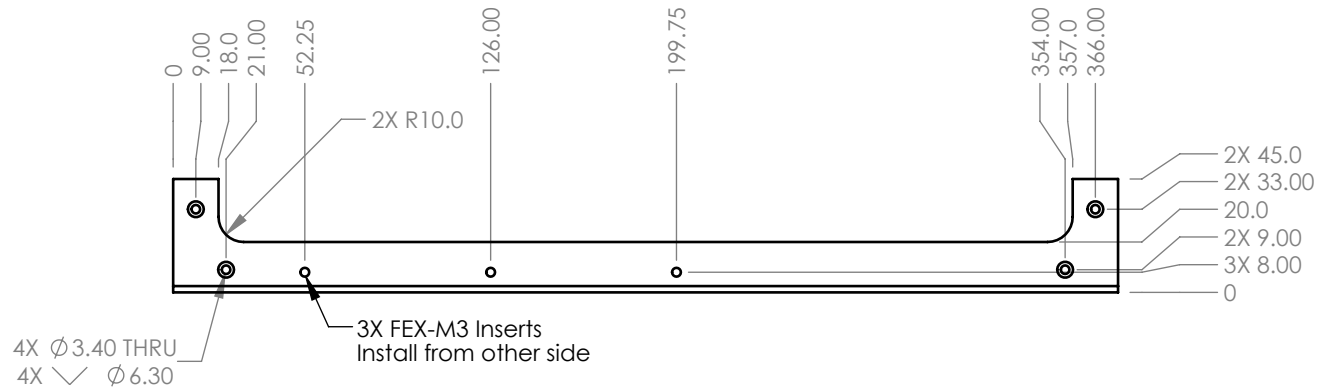

TITLE		Left Plate, Mini	
SIZE A	DWG NO. PP-FP0055	REV. D	
SCALE 1:3	DO NOT SCALE DRAWING	SHEET 2 OF 3	

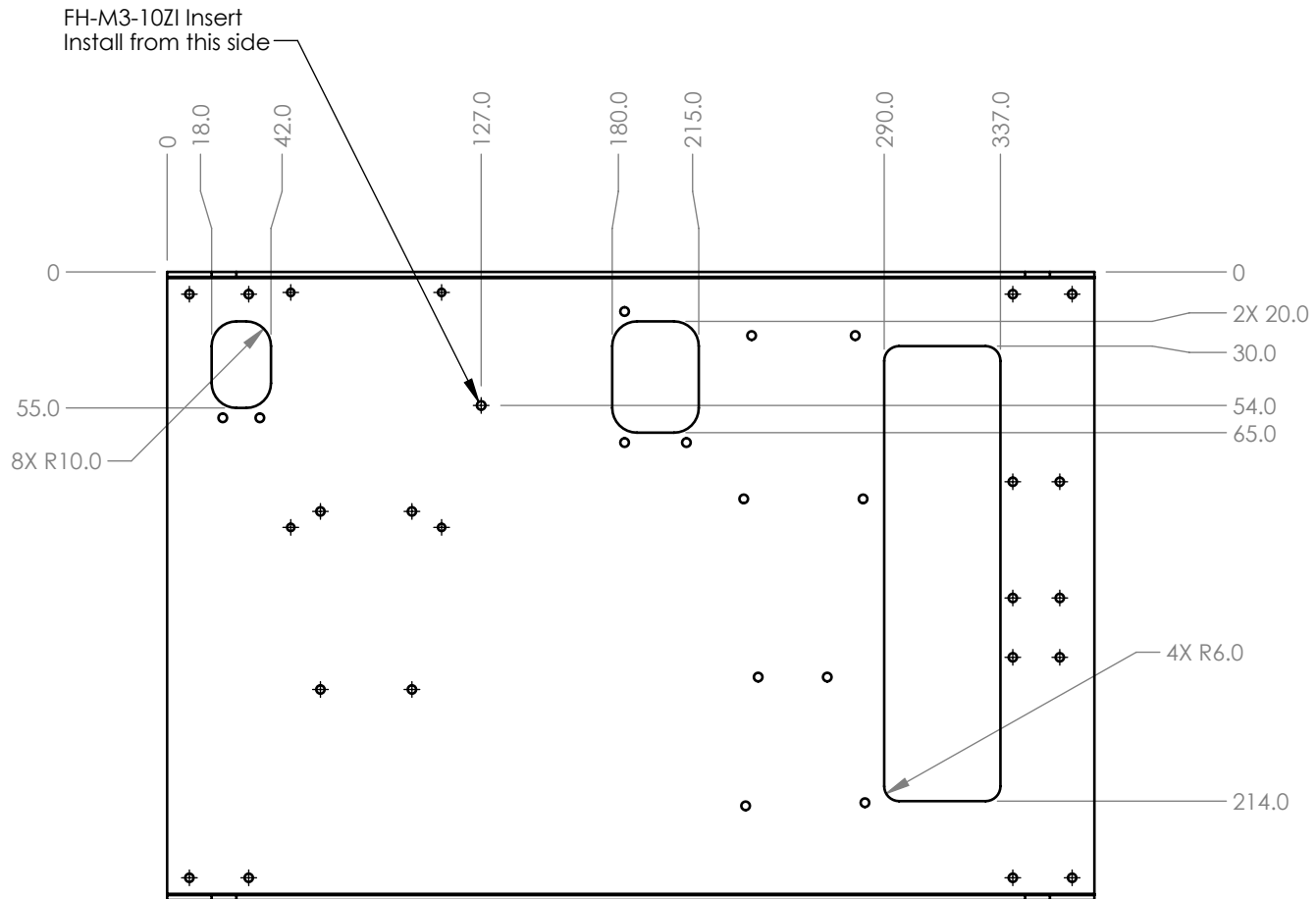

TITLE		Left Plate, Mini	
SIZE A	DWG NO. PP-FP0055	REV. D	
SCALE 1:3	DO NOT SCALE DRAWING	SHEET 3 OF 3	