

# RAMBo (R)epRap (A)rduino-(M)ega-compatible (M)other (Bo)ard

reprap.org/wiki/Rambo

RepRap / 3D Printer / CNC Electronics

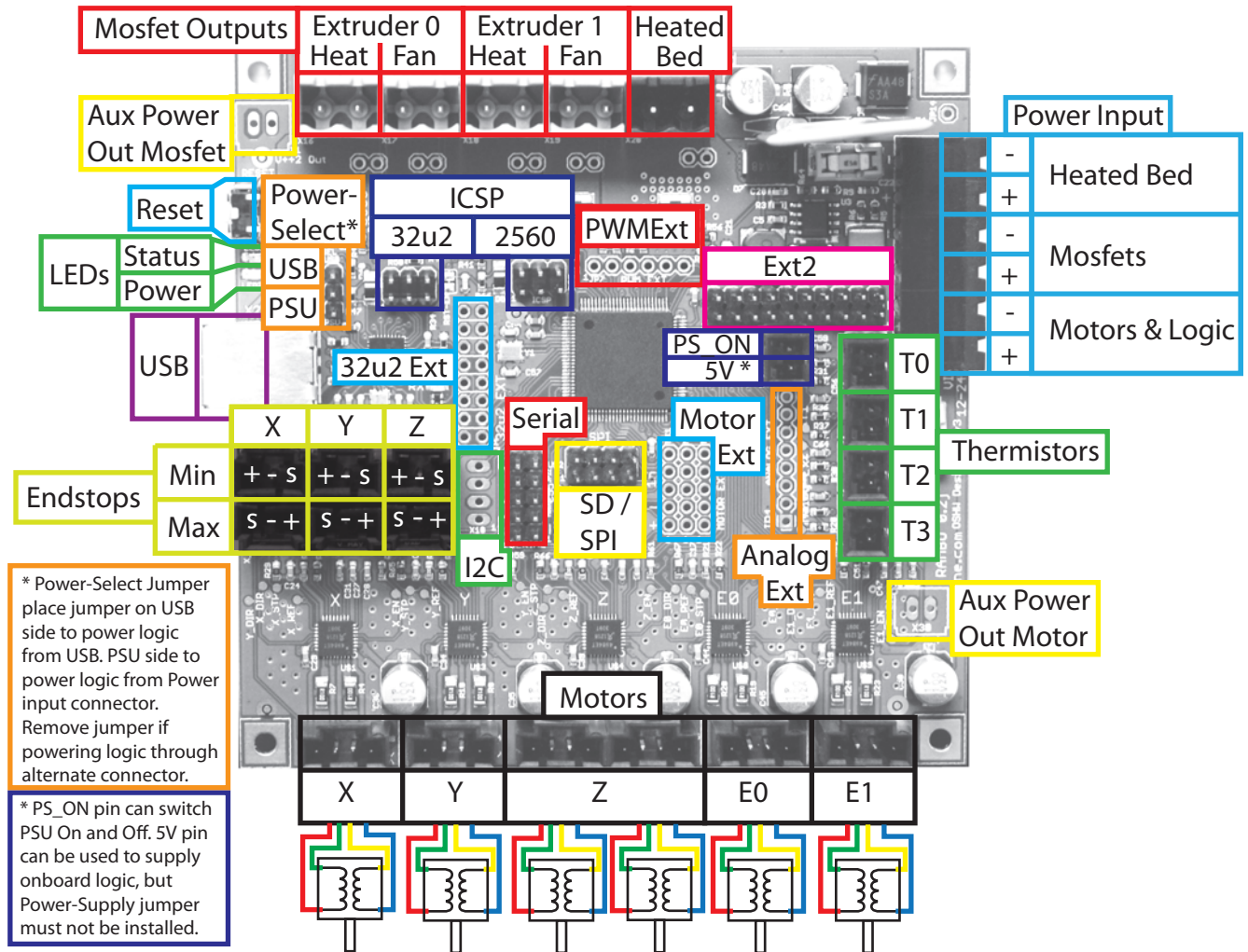

Handle with care. Static Sensitive device.

!!! Reversing input power can destroy electronics and cause fire hazard!!!

Test all electronics thoroughly before placing into service.

Do not leave power supplied to electronics unattended, or run machines unattended due to the risk of fire and malfunction.

This is NOT a toy and it contains small and sharp parts. Children can choke or suffocate by swallowing small objects. Keep all parts away from children and never leave printer/parts unattended.

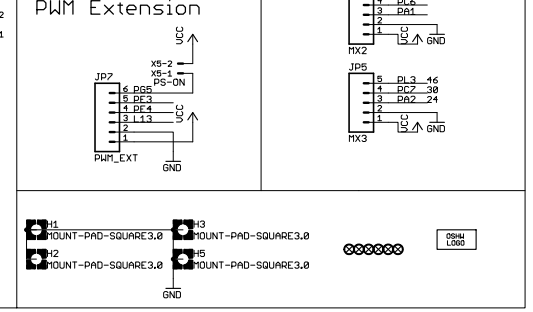
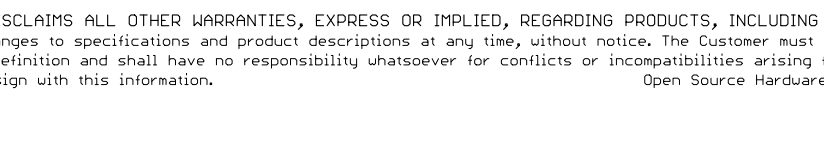
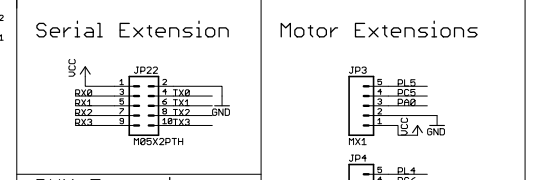
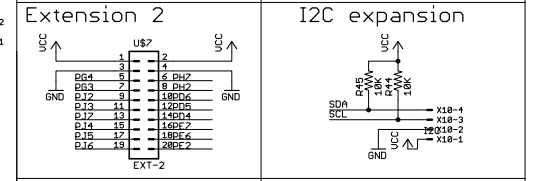
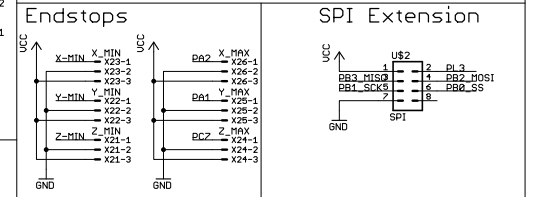
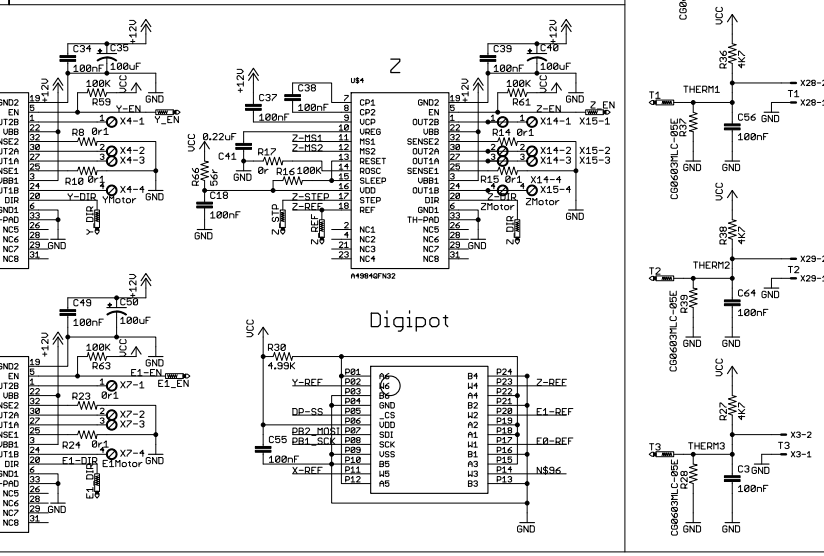
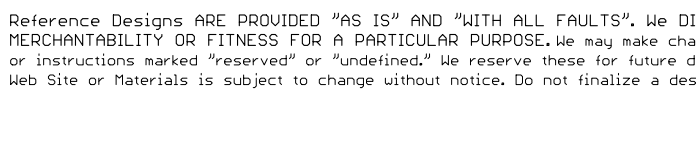
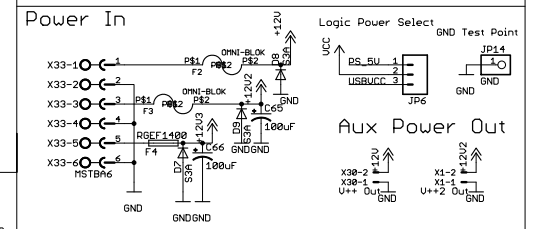
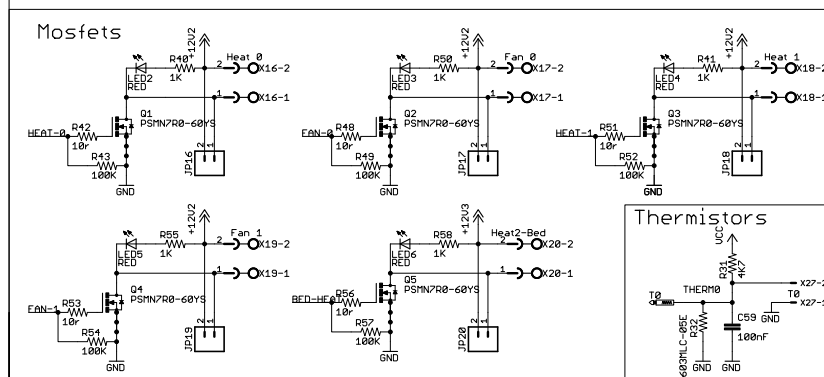
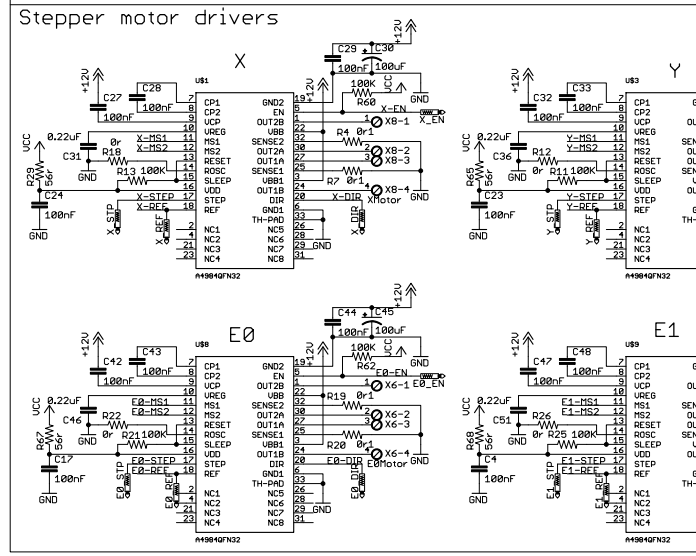
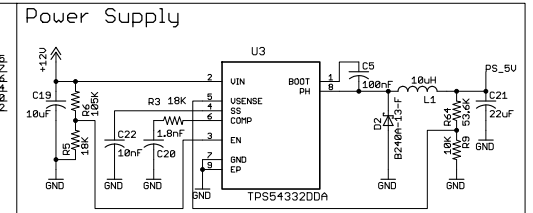
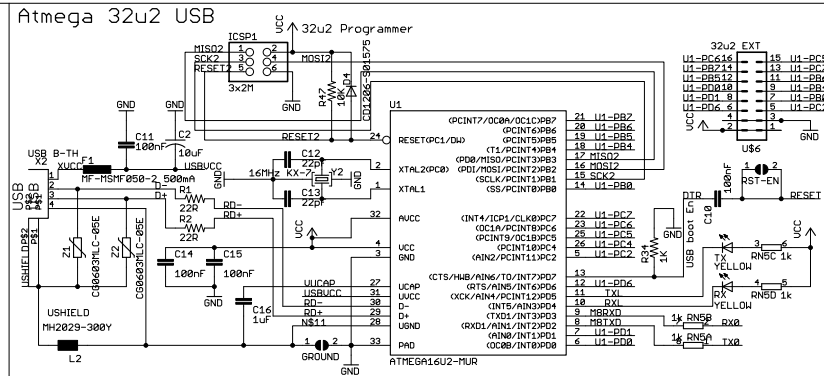
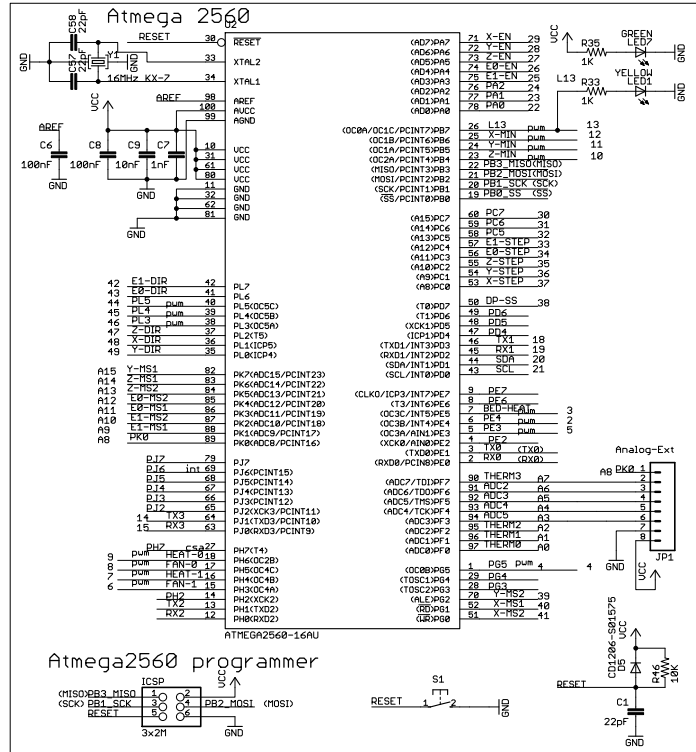

Reference Designs ARE PROVIDED "AS IS" AND "WITH ALL FAULTS". We DISCLAIM ALL OTHER WARRANTIES, EXPRESS OR IMPLIED, REGARDING PRODUCTS, INCLUDING BUT NOT LIMITED TO, ANY IMPLIED WARRANTIES OF MERCHANTABILITY OR FITNESS FOR A PARTICULAR PURPOSE. We may make changes to specifications and product descriptions at any time, without notice. The Customer must not rely on the absence or characteristics of any features or instructions marked "reserved" or "undefined." We reserve these for future definition and shall have no responsibility whatsoever for conflicts or incompatibilities arising from future changes to them. The product information on the Web Site or Materials is subject to change without notice. Do not finalize a design with this information.

Open Source Hardware Copyright 2012 - UltiMachine -Johnny,Britt,Dorothy,Lee